



GASBOY

SERIES 1000

FUEL MANAGEMENT SYSTEM

CARD ENCODING MANUAL

C08924

GASBOY INTERNATIONAL LLC

GASBOY

SERIES 1000

FUEL MANAGEMENT SYSTEM

CARD ENCODING MANUAL

C08924

Rev. 03/07/03

GASBOY INTERNATIONAL LLC
LANSDALE, PA

Copyright 2003 by Gasboy International LLC
All rights reserved.

The information in this document is confidential and proprietary. No further disclosure shall be made without permission from Gasboy International LLC

Gasboy International LLC believes that the information in this document is accurate and reliable. However, we assume no responsibility for its use, nor for any infringements of patents or other rights of third parties resulting from its use. We reserve the right to make changes at any time without notice.

CONTENTS

Section 1:	INTRODUCTION.....	1-1
Section 2:	THE CARDS	
	Specifications	2-1
	Single Versus Dual Cards	2-1
Section 3:	CARD LAYOUT AND FIELD DESCRIPTIONS	
	Card Type (Mag Card Only).....	3-1
	System ID.....	3-1
	Start Field Separator (Mag Card Only)	3-1
	Card Number.....	3-2
	ID Field 1 and ID Field 2.....	3-3
	Supervisor Card Option	3-3
	End Field Separator (Mag Card Only).....	3-4
	Expiration Date (Mag Card Only)	3-4
	Product Limitation Code	3-4
	Product Authorization Code	3-5
	Manual Entry Check Digit (Mag Card).....	3-6
	Manual Entry Check Digit (Optical Card)	3-6
	Manual Entry Definitions	3-6
	Card Layout to Match "A" System	3-8
	System ID.....	3-8
	Card Number	3-8
	Data Fields	3-8
	Product Authorization.....	3-8
	Product Limitation	3-9
	Additional Entries/Check Digit.....	3-9
	PIN	3-9
Section 4:	CARD ENCODING FORM.....	4-1
Section 5:	ORDERING ENCODED CARDS FROM GASBOY.....	5-1
Section 6:	ENCODING MAG STRIPE CARDS.....	6-1
Section 7:	ENCODING OPTICAL CARDS	7-1
	Card Punch Machine.....	7-3
	Card Punching Form	7-5
	Card Punching Example.....	7-6
Section 8:	CARD EMBOSSING	8-1
	WARRANTY	

Figures and Tables

Figures

7-1.	Optical Card Bit Position.....	7-2
7-2.	Manual Card Punch Machine	7-3
7-3.	Key Diagram	7-4
7-4.	Sample Punched Card	7-8

Tables

3-1.	Product Limitation Codes	3-4
3-2.	Product Code Assignments	3-5
3-3.	Product Authorization Codes.....	3-5
3-4	Required Manual Entries	3-6
7-1.	Optical Card, Five Bit Code Table	7-2

Section 1

INTRODUCTION

Access to the GASBOY Series 1000 System is controlled through the use of specially encoded cards. The GASBOY Series 1000 Card Encoding Manual provides instructions for:

- Compiling the information to be encoded on the Series 1000 fuel access cards.
- Encoding the information onto the cards, or
- Completing the GASBOY Card Encoding Order Form to have the cards encoded by GASBOY.
- Embossing the cards.

IMPORTANT

The GASBOY Series 1000 System is available with either a magnetic stripe (mag stripe) or an optical card reader. Mag stripe cards have information encoded on a magnetic stripe on the back of the card. Optical cards use a series of holes punched in the card to encode the information. This manual covers both types of cards. Follow the instructions for the type of card reader in your Series 1000 System.

It is important to follow the instructions in this manual carefully so that your encoded cards will work correctly with your Series 1000 System. If you need assistance, contact your local GASBOY distributor.

THE CARDS

SPECIFICATIONS

Card Dimensions: 3 3/8" x 2 1/8"

Card Thickness: .032" maximum (Mag Card)

.040" maximum (Optical Card)

NOTE: With dual card optical systems, both cards are inserted into the card reader simultaneously. Therefore, the combined total thickness cannot exceed .040". Cards supplied by GASBOY measure .030" for single cards, and .018" for dual cards.

Mag Stripe: ABA Track II

SINGLE VERSUS DUAL CARDS

A Series 1000 System can have its encoded information on one or two cards. When a single card is used, all of the information is encoded on one card. This is typically used when a vehicle is assigned to only one driver, or in a retail application when only an account number needs to be identified. A card encoded as a single card cannot be used as a dual card.

When dual cards are used, the information is separated onto two cards. For example, employee information is encoded on one card and vehicle information is encoded on another. Some data is encoded on both cards. This makes it possible for employees to operate different vehicles, and yet have both numbers identified. Dual cards must be used together; neither card will be accepted independently.

Section 3

CARD LAYOUT & FIELD DESCRIPTIONS

All Series 1000 cards are encoded with information to control access to the fuel dispensing equipment, the type of fuel(s), and the maximum amount of fuel dispensed.

If you have standard mag or optical cards, the system provides two variable identification fields so you can customize the system to your particular information requirements. The names and sizes of these variable fields must be specified at the time of order. You may also specify which card(s) the various information fields are encoded on in a dual card application.

If you are encoding optical cards to match a GASBOY "A" System, the number and type of digits to be encoded on a card varies according to individual customer requirements which are specified at the time of order. The majority of this section covers standard mag and optical cards. Encoding "A" system cards is discussed at the end of this section.

NOTE: You should have received a custom-tailored card layout along with a letter acknowledging your order and providing installation guidelines. This layout details each data field on the card and shows single and dual card formats (if applicable). Since field sizes may vary between systems, it is important that you follow your specific card layout. Your card layout is your most important reference when preparing your card information and encoding your cards.

LAYOUT FOR STANDARD MAG AND OPTICAL CARDS

This section describes the information fields encoded on the cards. Fields which indicate **MAG CARD ONLY** pertain only to mag card systems and should be ignored when using optical punched cards. If your Series 1000 is configured to match a CFN system, pay special attention to the italicized notes ***Series 1000 - CFN Card Compatibility***. Reference your Card Layout as you read through the descriptions.

Card Type (Mag Card Only)

Card Type is a one- or two-digit field which is always the first field encoded on the card. The Card Type field is always encoded with field separators. One field separator indicates a single card; the system will not prompt for an additional card for system access. Two field separators indicate a dual card (e.g., employee card). The system will prompt for a second dual card (e.g., vehicle card) before allowing access.

System ID

System ID is a four-digit field which identifies your system and prevents access by users of other systems. Your unique system ID is indicated on your card layout. When using two cards, the system ID is encoded and verified on both cards.

Series 1000 - CFN Card Compatibility

Your Series 1000 may have a five- or six-digit ID field if it has been configured to match a CFN System with a five- or six-digit system ID. See your Card Layout.

Start Field Separator (Mag Card Only)

One field separator is encoded after the system ID to indicate the beginning of identification field data.

Card Number

Card Number is a four-digit field which is used to lock out cards from access to your system. When using dual cards, the card number is usually encoded on only one card. In dual card mag systems, field separators take the place of the card number on the other card. In optical card systems, all of the holes are punched in the card number position on the other dual card. If the card number is encoded on both cards, it must be the same on both cards. You should assign card numbers sequentially from 0001 to facilitate card administration.

If you have the Fuel Delivery and Dipstick Card option, cards encoded within the range 9980 to 9989 initiate a fuel delivery transaction; cards encoded within the range 9990 to 9999 initiate a dipstick reading transaction. If you have the Supervisor Card option on an optical card system, any card within the range 9960 to 9979 is treated as a supervisor card.

ID Field 1 and ID Field 2

The Series 1000 System can have two variable identification fields whose combined total digits can range from nine for optical systems to 12 for mag card systems. When using dual cards, each ID field is usually encoded on a separate card. In dual card mag systems, field separators take the place of the corresponding ID field on the other card; in dual card optical systems, all of the holes are punched in the field position on the other card. If ID Field 1 or 2 appears on both cards, the ID field data must be the same on both cards. Check your Card Layout to determine exactly how your particular system is configured.

Supervisor Card Option

This option allows the system operator to use a specially encoded supervisor card to manually enter card information at the Series 1000 keypad. Supervisor cards are typically used when a card has been lost. The supervisor can enter data in one to three of these fields: card number (mag only), Field 1 and Field 2.

Supervisor Option - Mag Card Systems

A supervisor card can be encoded with special characters (**A** or **E**) that designate which fields (Card Number, ID Field 1, or ID Field 2) should be entered manually. The fields to be manually entered must be filled with either all **As** or all **Es**.

For example, assume that your system has the following card layout:

F S	SYSTEM ID	F S	CARD NO.	FIELD1 (EMP)	FIELD 2 (VEH)	F S	EXP. DATE	PROD LIM.	PROD AUTH.	CHECK DIGIT
-	XXXX	-	XXXX	XXXX	XXXX	-	YYMM	X	X	X

X = digit (0-9), FS = field separator

If you want to have the supervisor enter Card Number, ID Field 1, and ID Field 2, encode the following in those fields:

F S	SYSTEM ID	F S	CARD NO.	FIELD1 (EMP)	FIELD 2 (VEH)	F S	EXP. DATE	PROD LIM.	PROD AUTH.	CHECK DIGIT
-	XXXX	-	AAAA	EEEE	AAAA	-	YYMM	X	X	X

If you want to have the supervisor enter only ID Field 1, encode the card as follows:

F S	SYSTEM ID	F S	CARD NO.	FIELD1 (EMP)	FIELD 2 (VEH)	F S	EXP. DATE	PROD LIM.	PROD AUTH.	CHECK DIGIT
-	XXXX	-	XXXX	AAAA	XXXX	-	YYMM	X	X	X

Supervisor Option - Optical Card Systems

Any card with a card number in the range 9930-9979 is treated as a supervisor card. When a supervisor card is used, ID Field 1 and ID Field 2 may be entered through the keypad. The data entered at the keypad replaces any data that may have been on the card in those fields. If you do not enter any data and just press ENT, the system uses the data from the card.

End Field Separator (Mag Card Only)

One field separator is encoded after the last ID field to indicate the end of identification data.

Expiration Date (Mag Card Only)

Expiration Date is a four-digit field assigned to establish a lifetime for the card. The first two digits represent the year and the last two digits represent the month. When using dual cards, the expiration date may be encoded on one or both of the cards. If the expiration date is encoded on only one of the cards, field separators take its place on the other dual card. If the expiration date is encoded on both cards, it must be the same on both cards. If you wish to encode the cards with a date in the distant future, you can code 1012 for December 2010. Your system can be configured through the **SC** command to ignore the expiration date on the card. See the *Series 1000 Operation Manual* for use of the **SC** command. In any case, a valid year (00-99) and a valid month (01-12) must be encoded on the card.

Series 1000 - CFN Card Compatibility.

Your Series 1000 System may not have an Expiration Date field if it was configured to match a CFN system without an Expiration Date field. See your Card Layout.

Product Limitation Code

The Product Limitation Code is a one-digit field used to restrict the maximum quantity of product dispensed per transaction. When using dual cards, the product limitation code is usually encoded on only one of the cards, typically a vehicle card. In mag card systems, a field separator takes the place of the digit on the other dual card. In optical card systems all of the holes are punched in the product limitation position on the other dual card. If the product limitation code appears on both cards, the code must be the same on both cards.

Product limitation is provided mainly as a safeguard to minimize accidental spillage. You can load into the system up to ten (0-9) limitation codes with quantities up to 99999. The vehicle card is generally assigned a limitation code with the nearest quantity greater than the vehicle's tank size. If the user dispenses fuel to the quantity limit of his card, the transaction automatically terminates. If the user wants additional product, he can initiate another transaction and dispense additional product up to the limit cutoff.

Series 1000 - CFN Card Compatibility.

Your Series 1000 may have been configured with a two-digit limitation code to match a CFN system with a two-digit code. In this case, the Series 1000 will internally convert the two-digit code to a Series 1000 one-digit code. If the first digit is zero, the product limitation will be determined by the second digit. If the first digit is not 0, the two digit code will be converted to limitation code 9. (Examples: 01=1, 04=4, 11=9, 23=9). See your Card Layout.

Complete Table 3-1, **Product Limitation Codes** prior to ordering or encoding your cards. Make sure the completed table is available at start-up so it can be loaded into your system at that time.

Table 3-1. Product Limitation Codes

Limitation Code	Limit Cutoff Quantity (5 Digits)
0	
1	
2	
3	
4	
5	
6	
7	
8	
9	

Product Authorization Code

The Product Authorization Code is a one-digit field used to specify the type(s) of fuel a card is allowed to access. When using dual cards, the product authorization code is usually encoded on only one card (typically the vehicle card). In mag card systems, a field separator takes the place of the digit on the other dual card. In optical card systems, all of the holes are punched in the product authorization code position on the other dual card. If the product authorization code appears on both cards, it must be the same on both cards.

You can load into the system, up to nine (1-9) authorization codes with up to nine fuel types per code. The user is permitted to access only the product type(s) loaded into the system for the authorization code encoded on his card. The authorization code **0** permits access to all fuels.

Complete Tables 3-2 and 3-3, **Product Code Assignments** and **Product Authorization Codes** before ordering or encoding your cards and before system start-up. First, assign a two-digit product code to each product controlled by your system. The Series 1000 can maintain inventories for up to eight products. Typically the product codes are numbered 01 through 08, but can be any number 01-99. Second, assign the product code(s) to the product authorization codes as you require. Make sure your completed product code assignments and authorization code table are available at system start-up, so they can be loaded into your system at that time.

Series 1000 - CFN Card Compatibility.

Your Series 1000 may have been configured with a two-digit product authorization code to match a CFN System with a two-digit code. In this case, the Series 1000 will internally convert the two-digit code to a Series 1000 one-digit code. If the first digit is 0, the product authorization will be determined by the second digit. If the first digit is not 0, all fuels will be allowed. Examples: 01=1, 04=4, 11=0 (all fuels), 34=0 (all fuels). See your card layout.

Table 3-4. Required Manual Entries

Code	Required Manual Entries
0	No manual entry required
1	Odometer entry required
2	Manual entry required
3	Odometer and manual entry required
4	PIN entries required
5	Odometer and PIN entries required
6	Manual and PIN entries required
7	Odometer, manual and PIN entries required

TABLE NOTES:

Odometer Entry requires the user to manually input the vehicle's odometer or hour meter reading via the keypad before dispensing product. The odometer reading appears in the transaction printout.

Manual entry is an optional feature available only if specified with the system order. Possible uses include recording oil usage, trailer numbers, etc. The manual entry is entered via the keypad and appears on the transaction printout.

Personal Identification Number (PIN) is a four-digit code calculated from the card number. The purpose of the PIN is to prevent unauthorized use of the card if it is lost or stolen. The number is input via the keypad and the cardholder cannot access fuel unless the proper PIN is entered.

CARD LAYOUT TO MATCH "A" SYSTEM

The optical card layout to match a GASBOY "A" System does not contain the same fields as the standard Series 1000 System. The number of digits varies depending upon how the "A" System was configured.

"A" System optical cards can contain up to 20 digits and are made up of the following:

System ID

System ID is a 1 to 6 digit field which identifies the user's system and makes the card unique to that system.

Card Number

The card number is not a required field for "A" System cards. If the card number field does exist, it can be anywhere on the card and is not limited to 4 digits. Lockout is not restricted to the card number field as in the standard Series 1000, instead, it can be on any ID field of four or more digits. The field being used for lockout must be specified at the time of order.

If you are using an "A" System card that does not use card number and the supervisor or delivery and dipstick option is required, the field that is used for lockout is also used to identify the supervisor, delivery, or dipstick. Ranges for supervisor, delivery and dipstick cards have the following digits at the end of the field: supervisor, 30-79; delivery, 80-89; and dipstick 90-99. These ranges are preceded by nines to the length of the field. For example, the range for a supervisor card for a 4-digit field would be 9930-9979; for a 5-digit field 99930-99979, etc.

Data fields

Data fields can be used to identify any category of information desired by the user. A Series 1000 can be configured to accept up to four ID fields to match an existing "A" System optical card. A common configuration contains Employee, Vehicle, and Card number fields of 4 digits each. You must designate the lockout field for "A" System cards at the time of order.

Product Authorization

Product Authorization is a one- or two-digit field used to specify the type(s) of fuel a card is allowed to access. It can be located anywhere on the card. The Series 1000 contains up to nine (1-9) authorization codes with up to nine fuel types per code. The user can access only the product type(s) loaded into the system for the authorization code encoded on his card.

If your product authorization code is two-digits, the Series 1000 internally converts the two-digit code to a Series 1000 one-digit code. If the first digit is 0, the product authorization is determined by the second digit. If the first digit is not 0, all fuels will be allowed. Examples: 01=1, 04=4, 11=0 (all fuels), 34=0 (all fuels). See your card layout to determine the length of your authorization code.

Tables 3-2 and 3-3, **Product Code Assignments** and **Product Authorization Codes** provide templates for you to enter the values used to make up the authorization tables for your Series

1000 System. These tables should contain the same or similar values as those on your "A" System. Make sure your completed product code assignments and authorization code table are available at system start-up, so they can be loaded into your system at that time.

Product Limitation

The Product Limitation Code is a one-digit field used to restrict the maximum quantity of product dispensed per transaction. It can be located anywhere on the card. The Series 1000 can contain up to ten (0-9) limitation codes with quantities up to 99999. When assigning limitation codes, choose one with the nearest quantity greater than the vehicle's tank size.

Table 3-1, **Product Limitation Codes** provides templates for you to enter the values used to make up the limitation tables for your Series 1000 System. These tables should contain the same or similar values as those on your "A" System. Make sure the completed table is available at start-up so it can be loaded into your system at that time.

Additional Entries/Check Digit

Additional entries (PIN, odometer, or manual entry) in a System "A" can be mandatory or regulated by a check digit. Mandatory entries must be specified at the time of order. If entries are regulated by a check digit, up to three different check digits may appear: PIN, odometer, and manual entry. A check digit is a digit on the card that indicates whether the user must make additional entries upon fueling. The check digits may be in any position on the card and each may contain a value of either 0 or 1, with 0=not required, and 1=required.

PIN

PIN is not required on a Series 1000 matching an "A" System; however, if it is used, it can be mandatory (specified at order time) or regulated by a check digit on the optical card. If the PIN is mandatory, all card users must enter a PIN to fuel; no check digit is required. PIN regulated by a check digit may be requested on an individual basis by setting the check digit value on the card to 1=required. If PIN is used, you must have specified at the time of order either the "A" system or CFN Series PIN calculation algorithm and the name of the field on which the PIN is to be calculated.

Section 4

CARD ENCODING FORM

The Card Encoding Form on the following page is provided to organize your card data for encoding. Use this form as a master form, and make copies as required.

Use your card layout and your product authorization, limitation, and manual entry tables as you complete the form. This is a general form for both optical and mag card systems. Cross off any fields which are not indicated on your card layout. The first column is provided to write reference information, (e.g., employee name, account name, etc). This column of information is not encoded on the card but may be embossed on the card.

Use a separate page for each card type (e.g., single, dual card 1, dual card 2) to avoid card encoding errors. When completing the form for a dual card indicate field separators or all holes punched, as applicable, in the columns which are not encoded on that card.

GASBOY 1000 SERIES CARD ENCODING FORM

CARD TYPE: SINGLE DUAL

SYSTEM-ID: _____

SYSTEM OWNER: _____

CARD COLOR: _____ EMBOSS (INDICATE FIELD(S)): _____

REFERENCE INFORMATION	CARD TYPE	F S	CARD NO.	FIELD 1	FIELD 2	F S	EXP. DATE	PROD LIMIT	PROD AUTH.	CHECK DIGIT
1.		-				-				
2.										
3.										
4.										
5.										
6.										
7.										
8.										
9.										
10.										
11.										
12.										
13.										
14.										
15.										
16.										
17.										
18.										
19.										
20.										

Section 5

ORDERING ENCODED CARDS FROM GASBOY

Encoded cards may be ordered from GASBOY through your GASBOY distributor. The Card Encoding Form must be completed and given to your distributor to be included with the card encoding order. Make sure the order information section of the form is also completed. See the GASBOY Card Price List for available card colors. Card encoding orders with insufficient information will be returned for correction. If you have any questions, please contact your GASBOY distributor.

*NOTE: If you are not encoding your own cards, skip to Section 8, **Card Embossing**.*

Section 6

ENCODING MAG STRIPE CARDS

Encoding your own mag stripe cards requires a device capable of encoding ABA Track II. A mag stripe card encoder is available from GASBOY (P/N C05911).

Once you have completed the Card Encoding Form, you are ready to encode your cards. To encode the cards, follow the instructions provided with your mag card encoder.

Section 7

ENCODING OPTICAL CARDS

Information is encoded onto the optical cards by using a special five-bit code. The code is unique to GASBOY systems and adds to the security of the system.

The card is divided into a top and bottom section as shown in Figure 7-1 on the following page. There is a maximum of 10 columns on each half of the card. Each column represents a digit of information. If your card layout has 19 digits of information, your card will have 19 columns. Your Card Layout shows the columns on your card and the digits with which they correspond.

There are five hole or bit positions for each column. Each hole position in a column has a designated bit number from 1-5 as shown in Figure 7-1. A column's digit value is represented by two bits or holes. Table 7-1 translates the decimal numbers (0-9) into two bits (holes) punched. Therefore, for each digit of information encoded on your card, there will be a column with two holes punched.

When using dual cards, the encoded information is separated onto two cards. For example, employee information may be on one card, and vehicle information on another card. If a 4-digit employee number is represented by columns 9-12, then on the vehicle card all five holes are punched for each of these columns. When the two cards are placed on top of each other and inserted into the system, the only holes appearing through both cards in columns 9-12 will be the holes punched in the employee card representing the employee number.

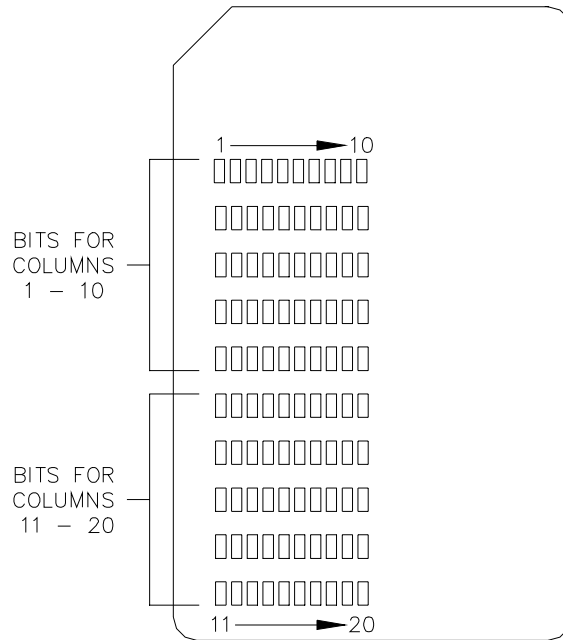

Figure 7-1. Optical Card Bit Position

Table 7-1. Optical Card, Five-Bit Code Table

DECIMAL	CODE BITS
0	2,4
1	1,4
2	4,5
3	3,4
4	2,3
5	1,3
6	3,5
7	1,2
8	2,5
9	1,5

CARD PUNCH MACHINE

Card punch machines may be purchased from your GASBOY distributor for punching your own cards. Manual card punch (P/N C01091) and electric card punch (P/N C01157) models are available. The main difference between the two models is the amount of pressure necessary on the keys to punch the card.

The following instructions show how to use either card punch. Refer to Figure 7-2 for the various components of the punch machine. Although the manual card punch is displayed, the same basic components apply to both models of card punches.

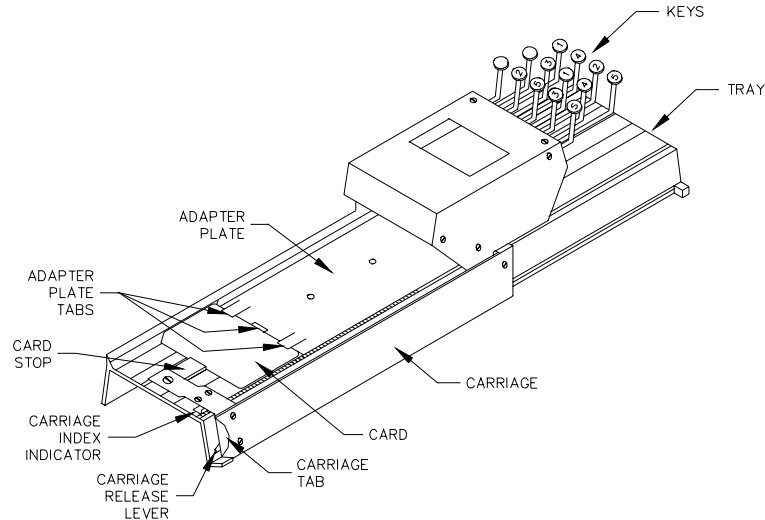

Figure 7-2. Manual Card Punch Machine

1. A special adapter plate is provided with the card punch to secure the card during punching. The adapter plate must be in place before punching can begin. Move the carriage to the far right by pushing the carriage tab on the lower left corner of the carriage.
2. On the right end of the tray, place the adapter plate flat in between the grooves. The turned up edge or lip of the adapter plate should be facing up and positioned at the top edge of the tray. The cut-out portion of the adapter plate should be positioned so that it surrounds the right end of the carriage.
3. Press in the carriage release lever, located next to the carriage tab on the lower left corner of the carriage, and move the carriage to the far left. You are now ready to insert a card.
4. Hold the card in your left hand with the long dimension of the card vertical and the cut corner to the top left. There are three tabs on the left edge of the adapter plate which secure the card. Insert the right edge of the card underneath the top and bottom tabs and on top of the center tab. With your right hand push the adapter plate (not the carriage) slightly to the right until the card lies flat. Let the adapter plate return so the left edge of the card slides into the notch in the card stop on the left end of the carriage.
5. After the card is secured in place, you are ready to punch a card. Push the carriage to the far right. This positions the carriage index indicator, located on the left side of the carriage, at the number 1 index position for the first digit of information to be punched.

6. The keyboard of the punch machine is marked 1-5, 1-5, S. As shown in Figure 7-3, the top keys numbered 1-5 are used for punching holes in the top columns on the card, while the bottom keys numbered 1-5 are used for punching holes in the bottom columns on the card. The S (or space) key is used for advancing to the next column after a digit of information has been punched. The S key is used for both the top and bottom half of the card.

Two keys are pressed for each column of information encoded on the card. The keys may be pressed sequentially or simultaneously. In a dual card application where all holes are to be punched, the keys 1, 2, 3, 4, and 5 should be pressed for each applicable column.

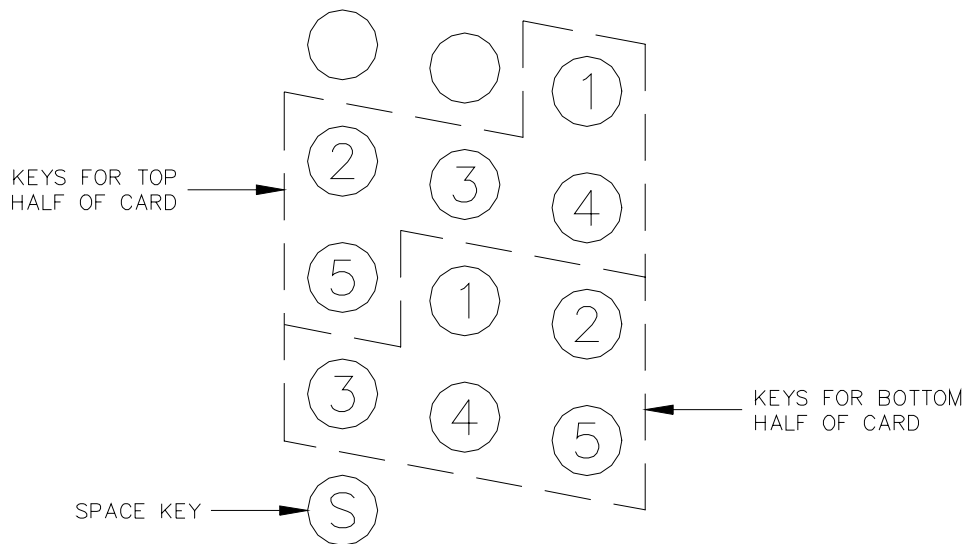

Figure 7-3. Key Diagram

CARD PUNCHING FORM

The Card Punching Form on the following page can assist you in encoding the data onto the cards. Use the form provided as a master form and make duplicate copies for worksheets. From your completed Card Encoding Form, fill in the digits to be encoded under the appropriate column numbers. Using the 5-bit code (Table 7-1), translate the digits into the 5-bit code and enter the two key numbers for the two bits (holes) that are to be punched (e.g., under the digit 6 write in 2,3). In a two card system, if all holes are to be punched write in 1-5 in the appropriate column(s). Shown below the bits is the index number the encoding machine indicates while the column is being punched.

CARD PUNCHING FORM

CARD HALF KEYS USED	TOP										BOTTOM									
COLUMN NO.	1	2	3	4	5	6	7	8	9	10	11	12	13	14	15	16	17	18	19	20
DIGIT NO.																				
KEY NOS. (BITS)																				
INDEX NO.	1	2	3	4	5	6	7	8	9	10	1	2	3	4	5	6	7	8	9	10

CARD HALF KEYS USED	TOP										BOTTOM									
COLUMN NO.	1	2	3	4	5	6	7	8	9	10	11	12	13	14	15	16	17	18	19	20
DIGIT NO.																				
KEY NOS. (BITS)																				
INDEX NO.	1	2	3	4	5	6	7	8	9	10	1	2	3	4	5	6	7	8	9	10

CARD HALF KEYS USED	TOP										BOTTOM									
COLUMN NO.	1	2	3	4	5	6	7	8	9	10	11	12	13	14	15	16	17	18	19	20
DIGIT NO.																				
KEY NOS. (BITS)																				
INDEX NO.	1	2	3	4	5	6	7	8	9	10	1	2	3	4	5	6	7	8	9	10

CARD HALF KEYS USED	TOP										BOTTOM									
COLUMN NO.	1	2	3	4	5	6	7	8	9	10	11	12	13	14	15	16	17	18	19	20
DIGIT NO.																				
KEY NOS. (BITS)																				
INDEX NO.	1	2	3	4	5	6	7	8	9	10	1	2	3	4	5	6	7	8	9	10

CARD PUNCHING EXAMPLE

The following is an example of a typical card punching application. The card information being punched is shown on the Card Encoding Form. Note that the fields and number of digits match the card layout. The Card Punch Form shows the card information translated into the 5-bit code. Step-by-step instructions are provided showing how to punch the information onto the card. The completed card is displayed so you can check if you punched the card correctly.

Customer's Card Layout

COLUMNS	1-4	5-8	9-12	13-16	17	18	19
FIELD NAME	SYSTEM ID	CARD NO.	Field 1 Employee	Field 2 Vehicle	PROD LIMIT	PROD AUTH	CHECK DIGIT
# DIGITS/FIELD	4	4	4	4	1	1	1
Single	xxxx	xxxx	xxxx	xxxx	x	x	x
Dual Driver Vehicle	xxxx xxxx	xxxx hhhh	xxxx hhhh	hhhh xxxx	h x	h x	h x

x means a digit (2 holes) is punched in the column.
h means all holes (5) are punched in the column.

Customer's Completed Card Encoding Form

FIELD NAME	SYSTEM ID	CARD NO.	ID Field 1	ID Field 2	PROD LIMIT	PROD AUTH	CHECK DIGIT
# DIGITS/FIELD	4	4	4	4	1	1	1
REFERENCE	9813	1141	6352	7413	3	2	1

Customer's Completed Card Punching Form

CARD HALF KEYS USED	TOP										BOTTOM									
	1	2	3	4	5	6	7	8	9	10	11	12	13	14	15	16	17	18	19	20
COLUMN NO.	1	2	3	4	5	6	7	8	9	10	11	12	13	14	15	16	17	18	19	20
DIGIT NO.	9	8	1	3	1	2	3	4	6	3	5	2	9	0	1	2	5	0	3	5
KEY NOS. (BITS)	1,5	2,5	1,4	3,4	1,4	4,5	3,4	2,3	3,5	3,4	1,3	4,5	1,5	2,4	1,4	4,5	1,3	2,4	3,4	1,3
INDEX NO.	1	2	3	4	5	6	7	8	9	10	1	2	3	4	5	6	7	8	9	10

<u>STEP</u>	<u>INSTRUCTIONS</u>	<u>DIGIT BEING PUNCHED</u>	<u>INDEX COUNTER</u>
1.	Insert card into the punch machine (cut corner top left)		
2.	Return carriage to Index 1		
3.	Press keys 1 and 5 of top keys <i>NOTE: Keys may be pressed sequentially or simultaneously</i>	9	1
4.	Press space key		
5.	Press keys 2 and 5 of top keys	8	2
6.	Press space key		
7.	Press keys 1 and 4 of top keys	1	3
8.	Press space key		
9.	Press keys 3 and 4 of top keys	3	4
10.	Press space key		
11.	Press keys 1 and 4 of top keys	1	5
12.	Press space key		
13.	Press keys 1 and 4 of top keys	1	6
14.	Press space key		
15.	Press keys 2 and 3 of top keys	4	7
16.	Press space key		
17.	Press keys 1 and 4 of top keys	1	8
18.	Press space key		
19.	Press keys 3 and 5 of top keys	6	9
20.	Press space key		
21.	Press keys 3 and 4 of top keys	3	10
22.	Return carriage to index 1		
23.	Press keys 1 and 3 of bottom keys	5	1
24.	Press space key		
25.	Press keys 4 and 5 of bottom keys	2	2
26.	Press space key		
27.	Press keys 1 and 2 of bottom keys	7	3
28.	Press space key		
29.	Press keys 2 and 3 of bottom keys	4	4
30.	Press space key		
31.	Press keys 1 and 4 of bottom keys	1	5
32.	Press space key		
33.	Press keys 3 and 4 of bottom keys	3	6
34.	Press space key		
35.	Press keys 3 and 4 of bottom keys	3	7
36.	Press space key		
37.	Press keys 4 and 5 of bottom keys	2	8
38.	Press space key		
39.	Press keys 1 and 4 of bottom keys	1	9
40.	Move carriage to the far left		
41.	Remove the card		

If the card is punched correctly, it should match the card shown below.

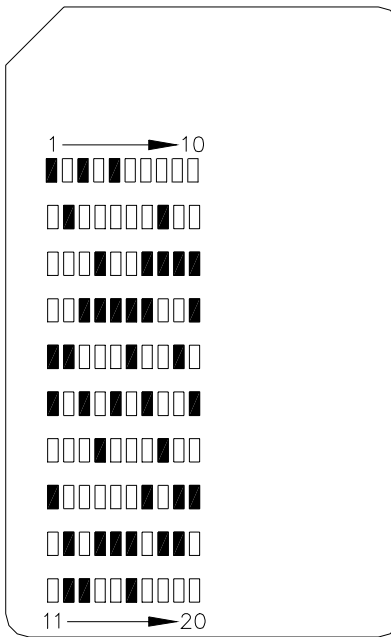

Figure 7-4. Sample Punched Card

Section 8

CARD EMBOSSING

The cards can be embossed with information (e.g., card number, account number, etc.) to visibly identify the card. On mag stripe cards, any area below 1 inch from the top of the card that encompasses the mag stripe may be embossed. On optical cards, any area below 1 1/4 inch from the top of the card containing the punched holes may be embossed.

An electric card embosser is available from GASBOY (P/N C02220). Please refer to the operating guide provided with the embosser for proper use.

If you are having your cards encoded by GASBOY, you may also specify information to be embossed on the card. In the order information section of the Card Encoding Form, indicate the information to be embossed.

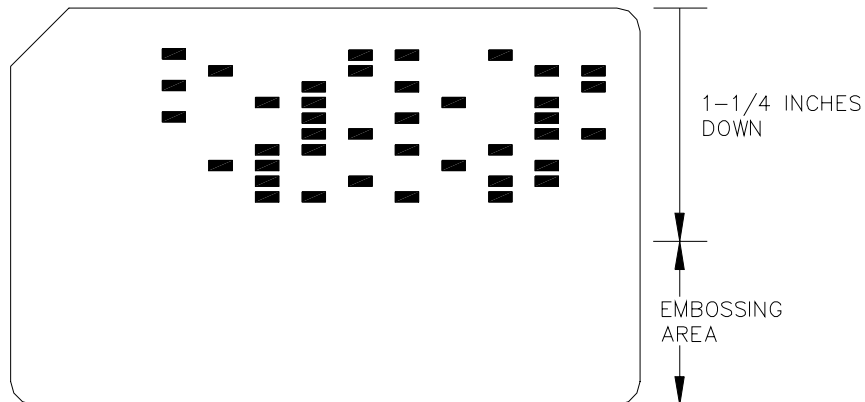

WARRANTY

General Statements:

Gasboy International LLC. warrants all new equipment manufactured by Gasboy against defective material and/or workmanship, for the warranty period specified below, when the equipment is installed in accordance with specifications prepared by Gasboy.

This warranty does not cover damage caused by accident, abuse, Acts of God, lack of surveillance of automatic recording systems, negligence, mis-application, faulty installation, improper or unauthorized maintenance, installation or use in violation of product manuals, instructions, or warnings. Under no circumstance shall Gasboy be liable for any indirect, special, or consequential damages, losses, or expenses to include, but not limited to, loss of product, loss of profits, litigation fees, or the use, or inability to use, our product for any for any purpose whatsoever.

Parts Only - During the warranty period, Gasboy will, at its option, repair or replace defective parts returned transportation prepaid to its factory.

On-Site Labor Included - Gasboy will also provide, within the Continental United States and during the warranty period, the services of an Authorized Service Representative (ASR) for on-site repair or replacement of defective parts.

Replacement Parts - Any system components that are not part of the original system order, including Island Card Readers, Pump Control Units, etc., are considered replacement parts.

Equipment	Term	Coverage
Commercial Pumps and Dispensers Full-Cabinet Consumer Pumps	One year from date of installation or 18 mos. from date of Gasboy International's invoice to the purchaser, whichever comes first.	Parts and Labor.
Small Transfer Pumps, Meters, Pressure Regulators	One year from date of installation or 18 mos. from date of Gasboy International's invoice to the purchaser, whichever comes first.- Excepting the Model 2020 Hand Pump, which has a 90-day warranty from date of GASBOY International's invoice.	Parts Only.
Keytrol	One year from date of installation or 18 mos. from date of Gasboy International's invoice to the purchaser, whichever comes first.	Parts and Labor.
Fuel Management Systems: - CFN/ Profit Point - Series 1000/Fleetkey - TopKAT - Fuel Point Readers (sold with new systems)	One year from date of start-up or 15 mos. from date of Gasboy International's invoice to the purchaser, whichever comes first.- The basic warranty only applies to systems which have been started up by a Gasboy Authorized Service Representative (ASR).	Parts and Labor.
Additional Fuel Point Items: - Fuel Point Readers sold for retrofitting existing systems. - Fuel Point vehicle and dispenser components.	One year from date of start-up or 15 mos. from date of Gasboy International's invoice to the purchaser, whichever comes first.	Parts Only.
Encoders, Embossers, Modems, CRTs, and Logger Printers	Purchased with Fuel Management System (Encoders, Embossers only): 90 days from the date of start-up by a Gasboy ASR, or 180 days from date of Gasboy International's invoice, whichever occurs first. Purchased with Fuel Management System (Modems, CRTs, and Logger Printers only): Matches system warranty. Purchased Separately: 90 days from date of Gasboy International's invoice to the purchaser.	Purchased with System (Encoders, Embossers only): Parts only. Purchased with System (Modems, CRTs, Logger Printers only): Matches system warranty. Purchased Separately: Parts Only.
Air Diaphragm Pumps	Three years from date of purchase (for full warranty description, see Price List).	Parts Only.
Items not manufactured by Gasboy (ex. automatic nozzles, hoses, swivels, etc.)	Not warranted by Gasboy International (consult original manufacturer's warranty).	Not Applicable.
Replacement Parts	One year from date of Gasboy International's invoice to the purchaser.	Parts Only.

To the extent permitted by law, this warranty is made in lieu of all other warranties, expressed or implied, including warranties of freedom from patent infringement, or merchantability, or fitness for a particular purpose, or arising from a course of dealing or usage of trade. No one is authorized to vary the terms of the warranty nor may anyone make any warranty of representation, or assume any liability other than that herein stated, in connection with the sale described herein. The acceptance of any order by Gasboy International is expressly made subject to the purchaser's agreement to these conditions.



GASBOY INTERNATIONAL LLC

P.O. Box 309, Lansdale, PA 19446 ● (800) 444-5579 ● FAX: (800) 444-5569 ● www.gasboy.com